



IMAGINE-B5G

Advanced 5G Open Platform for Large Scale Trials and Pilots across Europe

IMAGINE-B5G Facility Description

Table of Contents

1. Norwegian Facility (Telenor, Nokia-Finland, University of Oslo)	2
1.1 Facility Overview	2
1.2 Key Features	3
2. Spanish Facility (Telefonica, Nokia-Spain, Funcación Valenciaport, UPV, Keysight)	8
2.1 Facility Overview	8
2.2 Key Features	11
3. Portuguese Facility (Altice LABs, Capgemini, Ubiwhere, IT-AV, Keysight)	16
3.1 Facility Overview	16
3.2 Key Features	17
4. French Facility (Eurecom, Samsung, AirBus, Keysight)	26
4.1 Facility Overview	26
4.2 Key Features	27

1. Norwegian Facility (Telenor, Nokia-Finland, University of Oslo)

1.1 Facility Overview

Telenor's 5G Experimentation Platform includes a central site in Fornebu as well as several edge and Radio Access Network (RAN) sites across Norway, which are interconnected by Telenor Norway's commercial transport network. Figure 1 shows the geographical distribution of Telenor's central and

edge sites. In addition, we also offer mobile autonomous solutions that provide on-demand 5G-network coverage that we call Network on Wheels.

The capabilities that the facility supports are as follows: (i) E2E network slicing (eMBB, URLLC, mMTC) , (ii) E2E network orchestration and service orchestration, (iii) cloud-native infrastructure, (iv) next generation 5G RAN, (v) 5G standalone (SA) core, (vi) next generation Firewall as a service.

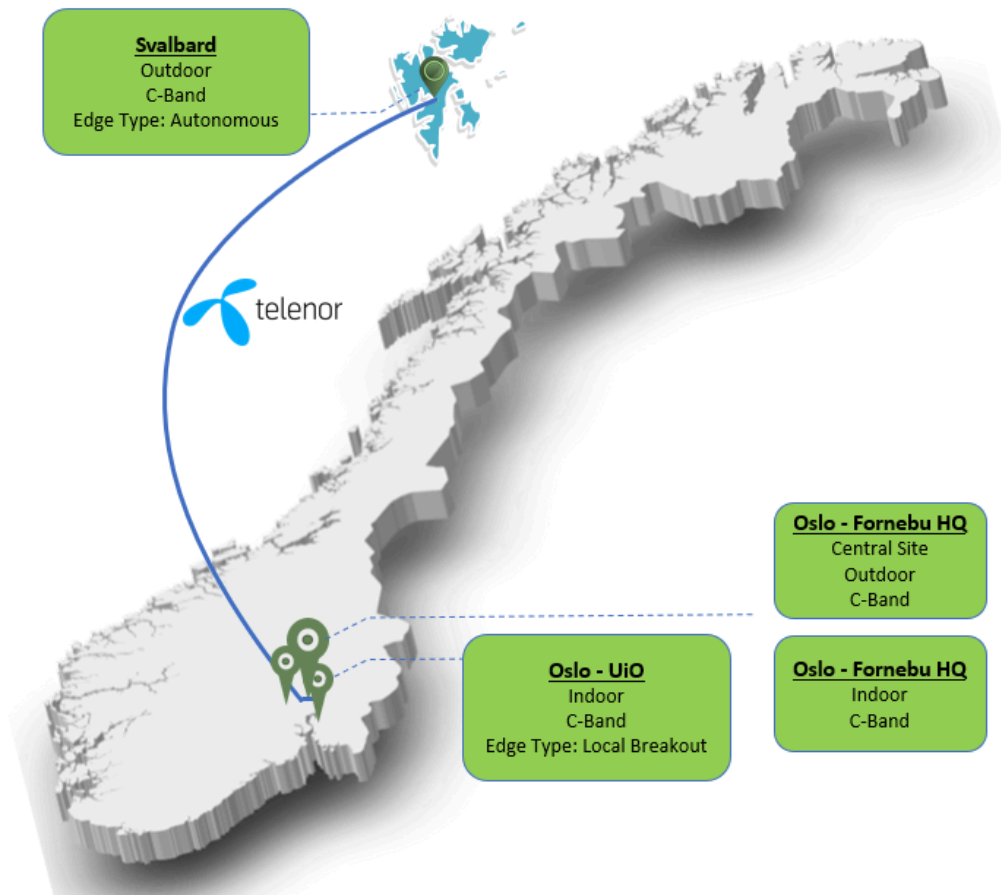

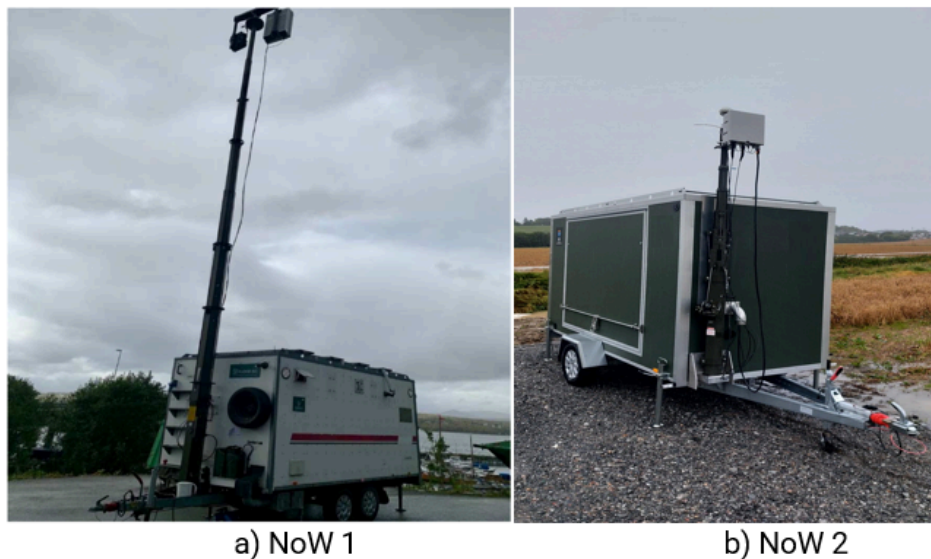
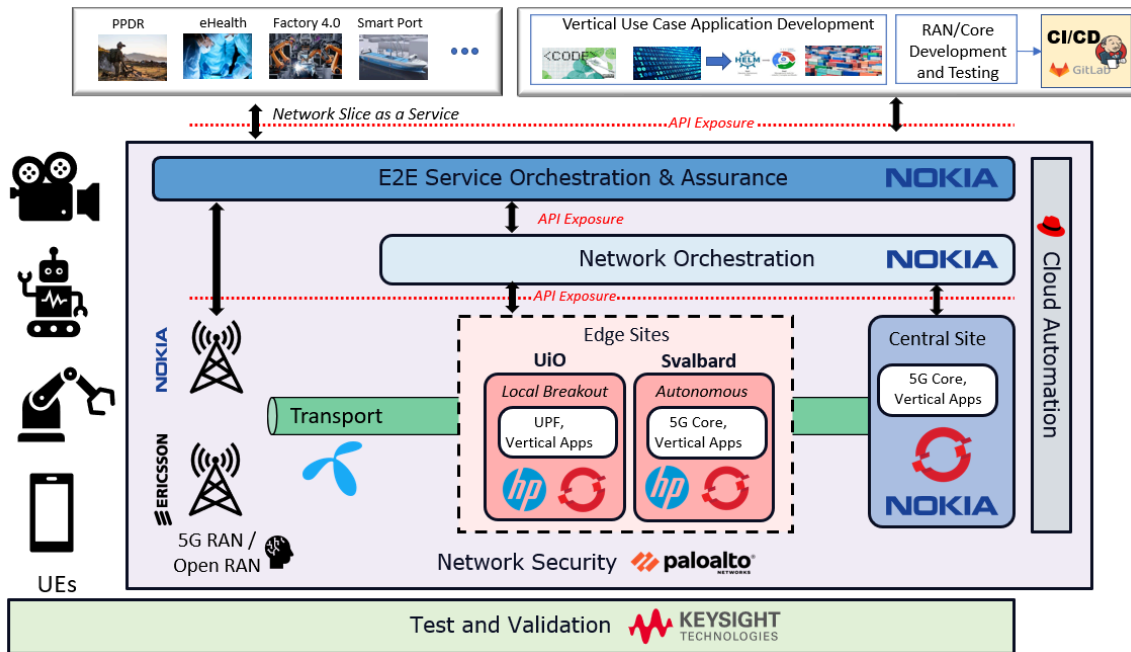

Figure 1: Geographical distribution (top), architectural components (center) and Network on Wheels (bottom) of the Norwegian facility.

1.2 Key Features

- Radio Infrastructure:** The facility constitutes multiple vendors regarding RAN equipment. The experimental sites are geographically distributed across various regions in Norway. The alternative key RAN sites that can support different vertical experiments are provided below and represented in Figure 1.
 - o Outdoor macro site at Fornebu, Oslo, connected directly to the core network without using commercial TN transport network.

- o Indoor site at Fornebu, Oslo, connected directly to the core network without using commercial TN transport network.
- o Outdoor macro site in Svalbard.
- o Indoor site at University of Oslo (UiO), Oslo, that will support the Sustainable Immersive Networking Laboratory (SIN-Lab).

Table 1: Basic radio site configurations

Site	Scope	Operational	Frequency NR	BW	Mode
Fornebu, Oslo	Outdoor	Yes	3.3 – 3.4 GHz	100 MHz	SA
Fornebu, Oslo	Indoor	Yes	3.3 - 3.4 GHz	100 MHz	SA
Svalbard	Outdoor	Yes	3.7 – 3.8 GHz	100 MHz	SA
UiO, Oslo	Indoor	Yes	3.3 – 3.4 GHz	100 MHz	SA

OC3 applicants must specify which site they will use. If applicants want to use PNI-NPN functionality, the option is to use Fornebu outdoor site together with Network on Wheels 1 (see last two paragraphs about Norwegian facility).

- **Core Network:** The 5G core network solution is compliant with 3GPP Release 16 5GC and the service-based architecture, containing all the fundamental independent, reusable, and independent 5G core network functions (AMF, SMF, UDR, AUSF, NSSF, NRF, PCF, UDM, UPF). The 5G SA core instances are deployed with CNFs jointly provided by multiple vendors, namely Oracle, ENEA, and Casa Systems.

Besides the central core at Fornebu, Oslo, two types of edge sites will be supported in the Norway facility: (i) an Autonomous edge, with a complete 5G core for resilience when connectivity to central site is cut off, at Svalbard; and (ii) a Local Breakout edge, with a UPF processing the traffic locally. The key edge sites planned to support vertical workloads at the edge are provided below.

- o Autonomous edge site in Svalbard
- o Local breakout edge, with a UPF processing the traffic locally, at UiO, Oslo, (SIN-Lab).

OC3 applicants must specify if and which edge to use.

- **Control, Management and Orchestration platforms:** The Norwegian facility has a full-stack orchestration, split in 3 levels of orchestration. Each level is supported by the respective components described below:
 - o Service Orchestration
 - Nokia’s Orchestration Center (NORC) is used for the E2E service orchestrator.
 - o Network Orchestration
 - Nokia’s NFVO, Nokia Cloud Operations Manager (NCOM), is used for managing the 5G SA core components across all sites.
 - o Resource Orchestration
 - RedHat Ansible Automation Platform. RedHat’s AAP is used to manage the orchestrate and compute infrastructure (e.g., computing and storage resources), but

also applicable for workload deployment. AAP is also being used to manage some of the network services' lifecycles, which are located at the network orchestration level, but with limited packaging options.

This orchestration solution allows automating the deployment of infrastructure, network services, and network slices, usually through Helm charts and Ansible playbooks. In addition, vertical applications can also be deployed automatically through this orchestration system once they are prepared and packaged accordingly.

OC3 applicants must specify which orchestration platforms and functions to use.

- Security Architecture:** The cloud-native CNFs are deployed majorly in two main clusters, management cluster and service cluster. Management cluster is used to deploy all the functions that are related to control and management such as NCOM and RedHat's AAP whereas the service cluster contains the rest of 5G core Network Functions (NFs). To isolate the traffic between different classes and to provide the zero-trust security, PaloAlto provides next generation Firewall as a service with features such as Intrusion Prevention System (IPS), data leakage protection, application and protocol decoding, encrypted traffic inspection, and signalling storm mitigation.

This is a default security architecture and cannot be altered by the OC3 applicants.

- Immersive Laboratory:** SIN-Lab located at UiO is a playground for immersive networking research that focuses on providing a true sensation of presence in the remote location through haptic interaction. SIN-Lab is equipped with a wide range of multimedia (cameras, LIDARs, headsets, VR glasses) and haptic devices (haptic gloves, in-air touch feedback, and haptic body suit by Rokoko) to support immersive applications. In addition, it features a robotic arm (UR10e from Universal Robots) and an advanced 5-finger dexterous robotic hand (by Shadow Robot). Using a different combination of the above equipment can be used to address a variety of verticals and use cases.

OC3 applicants must specify which devices they will use from the available lists.

- Portal/APIs:** On top of the full-stack management and orchestration, the Norway facility is also equipped with a BSS to interface with customers for ordering slice services. This BSS is integrated with NOrc using the TM Forum OpenAPIs listed in Table 2. Currently, mainly TMF641 is activated for service ordering, by default. The use of other APIs will be activated depending on the use case requirements.

OC3 applicants must specify which other APIs they want to use, beyond the default.

Table 2: APIs available in the Norwegian facility

Component	API	Purpose
NOrC	TMF633 Service Catalog API	It allows the management of the Service Catalog Elements lifecycles, and information on the service catalog elements for the ordering process.

	TMF641 Service Ordering Management API	The service Order can be created based on service that is defined in a catalog. Service Order Operations: creation, deletion, change
	TMF645 Service qualification API	Provides service availability at Customer location.
	TMF638 Service inventory API	Provides a consistent/standardized mechanism to query and manipulate the Service inventory.
	TMF639 Resource inventory API	Provides a consistent/standardized mechanism to query and manipulate the Resource inventory.

- **Nomadic 5G Private Networks – Network on Wheels:** Telenor Research and Innovation’s Network on Wheels (NoW) hosts the radio, core, and other applications as a one in all mobile solution that can be transported easily. It can be used in remote areas with no coverage or in areas where the connectivity infrastructure has been damaged due to natural disasters. Following are key advantages and functionality of NoW.
 - Coverage on demand with guaranteed QoS
 - Compute at the Edge
 - Fully autonomous
 - Quick to deploy, simple to operate.
 - Possibility to connect partner’s edge.
 - Secure and ruggedized
 - Multichannel backhaul connectivity via Commercial operators/Satellite.

We offer two different versions of NoWs: NoW1, and NoW2. The radio parameters of each NoW are summarized in Table 3. Each version uses a different 5G core supplier. NoW 1 uses a core provided by Athonet (now HPE) as a software solution running on a ruggedized server with a minimum footprint (PriMo solution). The strict requirements of PPDR scenarios imply that not only the 5GC software (SW) is programmed to include self-healing and resilient capabilities, but also the HW hosting the SW needs to be lightweight, robust, and resistant. NoW2 uses Microsoft Azure Private 5GC “AP5GC” that runs on an Azure Stack Edge “ASE” unit.

Table 3: Basic NoW radio configurations

Version	Scope	Radios supporting different frequency bands
NoW 1	Outdoor (To be extended with PNI-NPN functionality from March 2025, connecting to a different site in the Norwegian facility)	N40, n77, n78, n79
NoW 2	Outdoor	N40, n77, n78, n79

Figure 1 provides the visual description of NoW1, and 2. Note that these NoWs are primarily operated individually, outside the management of the main experimental platform described in Figure 1.

- **5G-NEPTUNE (5G-and-beyond Network Extensions towards Public neTwork integrated non-pUblic NETworks):**

The Norwegian facility platform extension from OC1 (5G-Neptune) will extend the IMAGINE-B5G Norwegian facility by providing Telenor with a new non-public 5G Core network (5GC) instance for Public Network Integrated Non-Public Network (PNI-NPN) experimentation, and by equipping Network on Wheels 1 (NoW 1) with an upgraded commercial-grade 5GC. The latter will include an IP Multimedia Subsystem (IMS), supporting Voice and mission critical related services required for verticals addressing critical communications and media distribution. 5G-NEPTUNE is also working on the design of solutions to integrate NoW 1 with Telenor's Experimentation Platform towards a Public Network Integrated NoW (PNI-NoW/PNI-NPN). 5G-NEPTUNE will also involve testing campaigns and an analysis of the obtained results, in collaboration with IMAGINE-B5G's partners, vertical stakeholders and/or open call experimenters from OC2/OC3 (in case if the extension is ready to be utilized), and with a focus on use case scenarios relevant to them. The platform extension will be ready around March 2025.

NoW1 will from March 2025 be equipped with a non-public core instance for public network integrated non-public network (PNI-NPN), as part of an upgraded commercial-grade 5G core. This means that NoW1 also will get an IP multimedia system (IMS), supporting Voice and Mission Critical related services (MCX). This could be used by any vertical interested in critical communications or media distribution. Furthermore, NoW1 will be integrated with a "public network" (Fornebu site, outdoor) as a PNI-NPN instance, and be available for testing.

OC3 applicants must specify which NoW to use, and/or, if IMS or PNI-NPN functionality will be used.

2. Spanish Facility (Telefonica, Nokia-Spain, Funcación Valenciaport, UPV, Keysight)

2.1 Facility Overview

The Spanish facility will comprise four sites: UPV campus and the port in Valencia, a rural site in Soria, and an experimental laboratory in Madrid. These sites are formed by different Radio Access Technologies (RATs) and independent 5G Cores and it will be evolved during the project to obtain an interconnected and distributed infrastructure.



Figure 2: Geographical distribution (top) and architectural components (bottom) of the Spanish facility

The UPV campus is formed by two cells, connected to the same 5G core, providing coverage around the campus (~0.1 km²), and located on the roof of two different UPV buildings. The cells have the same radio configuration, operating on the same frequency band, enabling the handover between them. The scenario has multiple environments for trials and use cases, such as sports fields, educational classes, gardens, and roads. Moreover, the UPV site has an immersive laboratory with telepresence, AR/XR, haptics and holographic equipment, with 5G SA coverage. Also, to perform trials and use cases where there is no 5G coverage, UPV has a portable 5G SA base station.



Figure 3: UPV site on campus coverage

In the Port of Valencia there is a mid-band 5G SA and mmW 5G NSA network providing coverage next to cruise berths, enabling to perform some use cases and trials in a port environment. The network is interconnected with the experimental laboratory in Madrid, where several KPIs from the core and energy data are storage and processing.



Figure 4: Valencia Port coverage

The rural site, covers an agriculture area and it aims to trial a zero emissions solution for monitoring and surveying agricultural sites, being fully powered by renewable energy, and providing connectivity to different IoT devices and HW to perform computation at the edge.



Figure 5: Rural site base station and coverage

The experimental laboratory located at Nokia’s premises offers an excellent environment to test various network solutions, configures and manages all sites, and provides a field trial with different technologies and frequency bands. The figure above shows the four Spanish sites and the reference architecture that can guide deployment and evolve the final architecture.

On this second OpenCall the UPV Campus and the Port of Valencia will be working on their interconnection through a dedicated fiber point to point, enabling high speed and low latency communication for performing use cases. Moreover, this facility will implement edge cloud based on hyperscaler stack, both in ‘private’ and ‘public’ flavours to adapt to different customer needs. The goal is to provide public network support to extend coverage for large scale trials. First, this facility aims to demonstrate the automation (AI-based) of 5G mobile core and use cases components deployment moving seamlessly from public cloud to operator edge/on-premises cloud and vice versa. Second, it aims to showcase the dynamic and automated adaptation of the network to changes in the public or edge clouds. The 5G private network and edge computing infrastructure will be used for testing the delivery of new services and applications in a private network environment, i.e., with specific SLAs and security requirements (through network slicing, in the radio as in the core). From an energy saving point of view, the data gathered by the IoT sensors will be processed in a computing continuum platform, which will optimize for the most energy efficient location for processing. The sites have IoT sensors to monitor the consumption of each 5G network component. The federated edge architecture will allow the coordination between the port of Valencia, UPV campus, the agricultural warehouses, and the experimental laboratory, which enables the optimization of the logistics of the transportation of the goods, improving energy efficiency at transportation.

This facility brings Telefonica as MNO. This allows that the facility has the following features: (i) advanced 5G connectivity, contributing to the extension of the private connectivity at the port of Valencia and UPV campus, and to enable access to private resources and use cases from the public 5G network; (ii) operators edge resources, contributing to the resource allocation on Edge Computing solutions at Valencia, and other locations based on hyperscalers solutions with same SW stack as in the public cloud; (iii) ZT management, contributing to its CI/CD platform to orchestrate ZT automated management (AI-based) of network and cloud resources.

2.2 Key Features

- Radio Infrastructure:** This facility will use the frequencies described in Table 4, where NSA and SA radio configurations will be supported to provide robustness and Carrier Aggregation capabilities as new modems with new features arrives to the market. Also, the use of mmW passive reflectors will be crucial to increase the coverage area. The radio supports remote automation tasks and reconfiguration to support Network-as-Code (NaC) concepts and methodology. Each facility has different frequency bands available to use, shown in the next Table. The radio hardware can configure radio slicing based on Physical Resource Blocks (PRBs) distribution and 5QI profiles with different and configurable priority levels.

Table 4: Radio frequencies/technologies available at Spanish facility

Site	Coverage	Frequency band NR	BW	Mode	Anchor LTE
UPV (Valencia)	Outdoor	26 GHz (n258)	800 MHz	NSA	2.6 GHz (B7)
	Outdoor	2.3 GHz (n40)	20 MHz	SA	-
	Indoor	3.6 GHz (n78)	100 MHz	SA	-
Port of Valencia (Valencia)	Outdoor	26 GHz (n258)	800 MHz	NSA	2.6 GHz (B7)
	Outdoor	Sub-6GHz	-	SA	-
	Outdoor	2.3 GHz (n40)	20-30* MHz	SA	-
Rural site (Soria)	Outdoor	2.3 GHz (n40)	20 MHz	SA	-
	Outdoor	3.5 GHz (n78)	100 MHz	SA	-
Experimental lab (Madrid)	Indoor	26 GHz (n258)	800 MHz	NSA	1.8 GHz (B3)
	Outdoor	2.3 GHz (n40)	20 MHz	SA	-
	Indoor/Outdoor	3.5 GHz (n78)	100 MHz	SA	-

- Core Network:** Spanish facility has each site with an isolated core which allows for sharing computational resources (based on the energy consumption or needs of the network) and NFs between the different sites. There are several 5G cores available to use: Open5GS (available at UPV, Port of Valencia, rural site, and Nokia experimental laboratory), Cumucore (available at UPV), and Amarisoft (only for laboratory testing purposes, available at UPV). To perform network slicing, different UPFs are deployed using isolated VLAN ID for being able to have a consistent E2E traffic priorities schema. The user database is able to assign 5QI profiles and a specific slice to each UE.
- Cloud, Edge Computing resources:** The site will include Multi-Access Edge computing instances based on microstack, with several edge computing resources with GPU capacity in the different points of presence that will be available for hosting private cores, industrial applications and KPIs monitoring. Valencia port for remote driving, UPV campus for immersive video and 180-360°

cameras, and the Soria rural site for IoT sensors information and cameras. This means that users from the use cases running at Valencia testbeds will have access to services and applications running in the private network using the public 5G Network from Telefonica. Additionally, Telefónica provides edge resources solutions available in the public Cloud and an on-premises server from AWS to have cloud continuum. Therefore, it will be possible to move workloads from AWS regions to UPVs on premises server or even it will be possible to have mixed scenarios where you can deploy some workloads on public cloud and the rest of the deployment can be done in the on-premises server. This solution will help on use cases that requires low latency, high computational resources, and storage. The novelty on this architecture is that the on-premises server is controlled by the same APIs of the AWS regions, this will make it easier to use the CI/CD tools to deploy (e.g., helm, terraform, ansible and Jenkins).

- Control, Management and Orchestration platforms:** This facility will provide MEC interconnectivity integration to secure inter-MEC communications using VPNs and MEC orchestration to provide required 5QI with QoS. Each application will have a different VPN server hosted in the MEC. Only remote operators with the required HW IMSI will be able to connect to the application, but the certificates will be only operative when the user is connected to a gNB in an authorized TRAC. At any moment, the network administrator could enable or disable a given IMSI access to a particular application in each TRAC. This additional feature will add a new security layer that must be orchestrated in a global way, as the certificates and TRACs are deployed in several private and the public core. The facility will support developers some APIs that will provide third parties easily access, discovery and use of the 5G network capabilities. The developers will be able to reach the Network as Code APIs (for more information: <https://www.nokia.com/networks/network-as-code/>) through the CAPIF interfaces by easily integrating these function calls in their services developments.

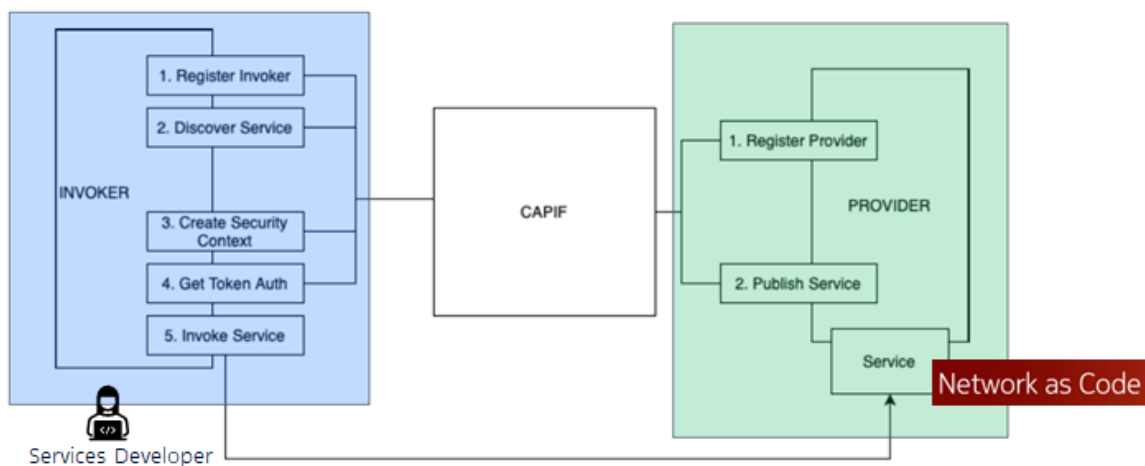

Figure 6: Integration between CAPIF and Network as Code

- Security Architecture:** In hybrid public-private 5G networks some applications could be exposed to public potential clients that requires additional security validations to avoid the new hybrid network vulnerabilities. For this purpose, a VPN server network will be deployed for each service instance that will deliver client certificates for remote operation and interaction with the different deployed applications. The network will provide management of client certificates that will be supported with additional features as TRAC. NaC methodology will be supported to automate tasks in the radio, the

transport, and the core to provide easy advanced control of the network to the application developers when needed and authorized.

- **Immersive Laboratory:** The immersive lab located at UPV is an experimental space with telepresence, AR/XR, volumetric/360° capture, haptics, and holographic technologies to host B5G human-centric use cases. The lab comprises specialized immersive equipment and portable setups that can be used outside the facility, with great accessibility either presential or remotely for application developers, integrators, and entities from different verticals. The communication of the immersive applications outside the lab are enabled by combining a federated edge architecture with 5G SA wireless connectivity (both indoor and outdoor).

The immersive equipment available, as seen in Figure 7, includes: (i) Brainstorm Multimedia chromas, holographic setups, and Alfalite LEDWall suited with specific processing hardware and software, allowing for subject insertion in immersive virtual sets with great realism; (ii) Head Mounted Displays (HMDs) for XR applications that combine virtual environments with real-life video via pass-through cameras (e.g. MetaQuest Pro); (iii) Evercoast volumetric video capture setup to create real-life 3D models of subjects; (iv) YBVR 360° video capture setup for immersive media experience of sports and events; (v) haptic gloves (e.g. bHaptics TactGlove) and suits (e.g. bHaptics TactSuit X40, OWO Vest) equipped with inertial measurement, gesture detection, wireless connectivity and tactile/kinesthetic feedback; (vi) Universal Robots UR5e arm and gripper suited for remote control from the haptic gloves; (vii) AGVs/AMRs (e.g. Robotnik Summit XL) equipped with RoboSense LiDAR and 360° cameras, teleoperated from indoor cockpits composed by wheels, pedals and HMDs; and (viii) holographic capture setups to record audio and video, together with holographic displays (which have been extended thanks to the OC1 Platform extension BiNetHol, described below).

The lab is divided in 2 locations or sub-labs, which are interconnected. One lab contains most of the resources and equipment, statically placed, with the highest performance capabilities (chromas, holograms, LEDwall, cockpits, haptics, HMDs, volumetric capture, and 360° capture) and the other lab space is focused primarily on portable telepresence and holograms, to test applications remotely. Additionally, a third space (a velodrome with 5G coverage) is available to test remote driving applications.

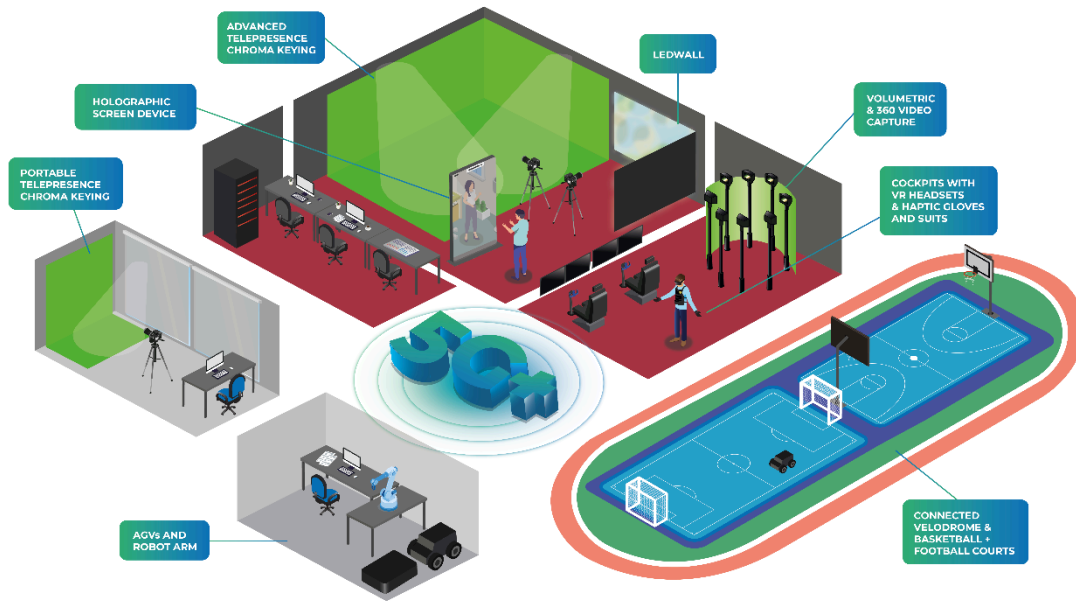

Figure 7: General view of the main UPV's lab equipment

- **BiNetHol: Bidirectional education system based on holographic cabins through 5G networks:**

The Spanish facility platform extension from OC1 (BiNetHol) will extend the IMAGINE-B5G Spanish facility by providing UPV with a capture and state of the art holographic display. This setup will allow UPV to test bidirectional, remote communication. A subject (e.g., the teacher/trainer) will be captured in some location. Then, their image and audio are processed locally or in the edge computing platform of the 5GA network. This image and audio are transmitted through the 5GA network to the holographic cabin, which can be located in a classroom, in which students can visualize and hear in real time a hologram of the teacher. Communication back to the teacher from the students is also possible, as the holographic cabin is equipped with front-facing camera, and microphone. This platform extension will enable the Spanish facility to test the quality of experience and KPIs of holographic communication through 5G networks for education and possibly other verticals. The platform extension also intends to perform real world vertical experiments involving a real classroom with students interacting with a remote teacher.

- **Portal/APIs:** The facility will support developers some APIs that will provide third parties easily access, discovery and use of the 5G network capabilities. The developers will be able to reach the Network as Code APIs through the CAPIF interfaces by easily integrating these function calls in their services developments.

The CAPIF Framework will be used by any developer to register and discover the available services APIs and generate the required tokens authorizations to interact with the 5G Network. In a similar way, the services providers like Network as Code will be registered in CAPIF to publish the availability of the services in different points of presence.

Currently the set of NaC and CAPIF APIs are exposing REST interfaces, through a web portal, all services, invokers and services providers registered in CAPIF can be managed, also APIs usage

will be tracked, during the project new functionalities will be added. The rest of the components (core, radio, MEC, and Grafana monitoring dashboard) have their own portal which could be accessible at administrator level through the OAM subnetwork with the appropriate certificates using their credentials.

- **Vertical/Developer/Exposure APIs:** NaC will provide several APIs to different functional developers depending on the kind of required functions. NaC will publish the following Services APIs:
 - *NaC_XaaS*
 - *NaC_Service_Developer*
 - *NaC_Application_Developer*
 - *NaC_Customer_Management*

The *Infrastructure as a Service NaC API* will provide access to the infrastructure manager to register new 5G network components or services that will be available to the developers. *The Customer Management NaC API* will provide information for clients' management including radio status and traffic reports (e.g., radio band and radio slice status or network KPIs). *The Services Developer NaC API* will provide a set of functions to manage the connected devices and to monitor the radio health and the network and application KPIs (e.g., IMSIs activation and authorizations, radio and slice status or network and application KPIs). The *Application Developer NaC API* will provide a set of functions applicable that will be used by the end-device connected application. The functions will provide information of the application KPIs and the connected radio (e.g., radio and slices status or network and Application KPIs). In addition, CAPIF has several APIs for the correct exposure and discovery of the available API to ease developers' tasks inside the network. The following table covers CAPIF APIs.

Table 5: CAPIF APIs available in the Spanish facility

API Name	Description
Discover API	Service used by Invoker to discover Services registered in CAPIF
Publish API	Service used by APF to publish new Services in CAPIF
Events API	Service used by all entities of CAPIF to receive notifications (New service Published, Provider removed, etc)
Invoker management API	Service to register new Invokers in CAPIF
Security API	Service used by Invokers to create security context and manage security auth between Invokers and Services
Logging/Auditing API	Services to save and consult logs of use when Invoker calls Service.
Provider management API	Service to register new Providers in CAPIF
Access control policy API	Service used by an API exposing function to obtain the access control policy from the CAPIF core function.
Routing Info API	Service used by an API exposing function to obtain the API routing information from the CAPIF core function

3. Portuguese Facility (Altice Labs, Capgemini, Ubiwhere, IT-AV, Keysight)

3.1 Facility Overview

The Portuguese facility features a platform that exploits a rich set of capabilities and characteristics that go beyond the mere aggregation of equipment. The overall infrastructure features both research and commercial graded solutions and open labs to provide a real-life city-wide environment for developing, integrating, and testing novel solutions for 5G and beyond technologies. The infrastructure is geographically distributed across the city area as shown in Figure 8 and encompasses various indoor and outdoor 5G NR deployments supported with different 5G Core and Edge Computing solutions. Besides enabling wireless communications, the deployment incorporates connected devices (e.g., CCTV cameras, user equipment, and IoT devices) which can be leveraged for the validation of 5G technologies. The sites covered by the infrastructure include seaport and railway areas, which makes it suitable for exploring Localization and Transportation use cases; industrial areas that could be leveraged for Industry 4.0 scenarios; city wide smart lampposts and fibre deployments that could be explored for PPDR use cases as well as to extend the reachability of the current resources towards other nearby verticals, notably care facilities for eHealth scenarios. An overview of the facility resources, use cases and targeted functionalities enhancements is provided in Figure 9. The heterogeneity of resources, with different technological readiness and customization levels falling into the domain of different organizations create an ideal environment for multi-domain, multi-technology solution development allowing to evolve all the way from concept to prototype to end-of-line validation.



Figure 8: Portuguese facility geographical distribution

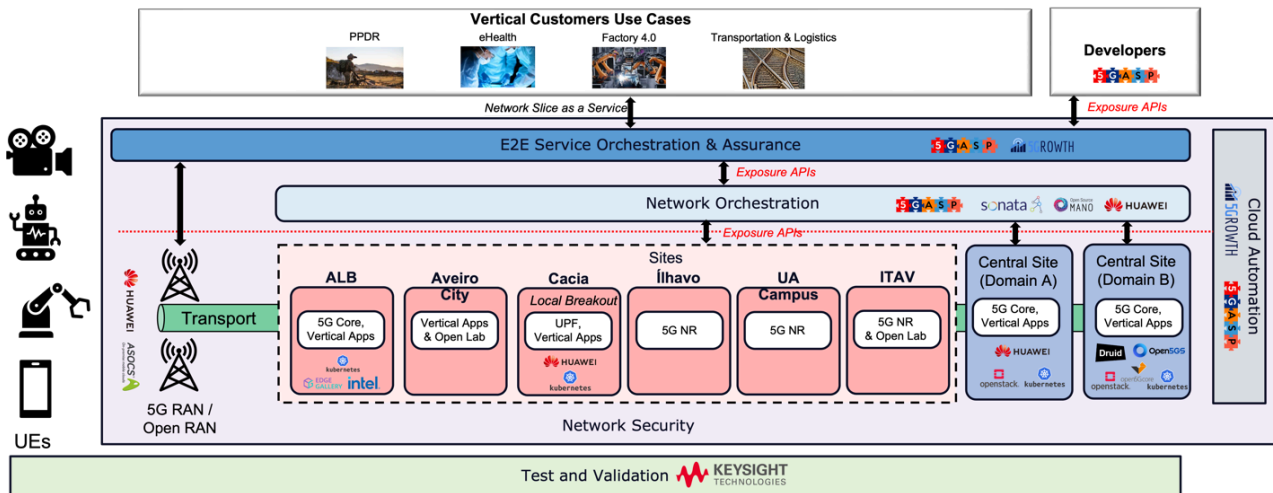

Figure 9: Portuguese facility architectural components

3.2 Key Features

- Radio Infrastructure:** The 5G RAN infrastructure bring different 5G NR sites (Figure 10) configured in the frequency band n78 with TDD transmission and center frequency 3790 MHz and bandwidth of 20 MHz as summarised in Table 6.

Table 6: Radio frequency configurations

Parameter	Value
DL Center Frequency	3790 MHz
Bandwidth	20 MHz
DL Frequency Start	3780 MHz
DL Frequency End	3800 MHz

Two indoor sites are deployed within the university campus: (i) the first one consists of two antennas (pRRU 5961) and is deployed in ITAV premises (ii) the second one consists of only one antenna and is deployed on one of the university electrical substations approximately 400m away. Both sites include a BBU 5900 and a RHUB 5963 that makes connection between the BBU and the antennas.

A third indoor site is deployed in an industrial location about 6km away from university campus and has a total of three lampsites (i.e., a BBU 5900, an RHUB 5963 and 3 pRRUs 5961) co-located with a 5G MEC platform providing an Edge UPF UL CL for LBO.

An outdoor site, 6km away from the university campus, is composed of three outdoor antennas (AAU 5649) placed on top of a tower and covering three different sectors. The AAUs are connected to a BBU 5900 which in turn is connected to the 5GC through a public L2 service.

In addition to the fixed sites, a portable site can also be deployed using a BBU 5900 and an RHUB 5963, connected to a pRRU 5961 antenna. This setup is compatible with an open-source core, allowing for flexible and rapid deployment in various locations. The portable site offers a

cost-effective solution for temporary or mobile connectivity needs, with the ability to integrate seamlessly into existing network infrastructures.

There is also a site at the headquarters of Altice Labs. This site follows the Open RAN (O-RAN) architecture, the gNB is disaggregated into 3 separate components: the Radio Unit (RU), the Distributed Unit (DU) and the Centralized Unit (CU), which can be deployed in multiple combinations.

The DU and CU components are based on ASOCS¹ CYRUS 2.0. ASOCS provides an open and fully virtualized software solution, delivering 5G for both LAN and WAN cellular network solutions and can run on a standard server or universal CPE. ASOCS CYRUS 2.0 uses standard Ethernet switches and commercial-off-the-shelf IT equipment. Attributes include O-RAN-defined 7.2 open Ethernet fronthaul interface, virtualized 4G/5G software-based solution and CU+DU implemented by software. The O-RAN - FH 7.2 interface is used to connect to radio. Figure 4 illustrates the functional splitting options deployed at the Aveiro 5G pilot site – fronthaul O-RAN 7.2 and midhaul 3GPP split 2 (F1 interface). Two solutions are available for the RU component – ASOCS indoor RU and Altice Labs indoor and outdoor RU. This solution is also available at the afore mentioned sites except for the industrial site. – ASOCS indoor RU and Altice Labs indoor and outdoor RU. This solution is also available at the afore mentioned sites except for the industrial site.

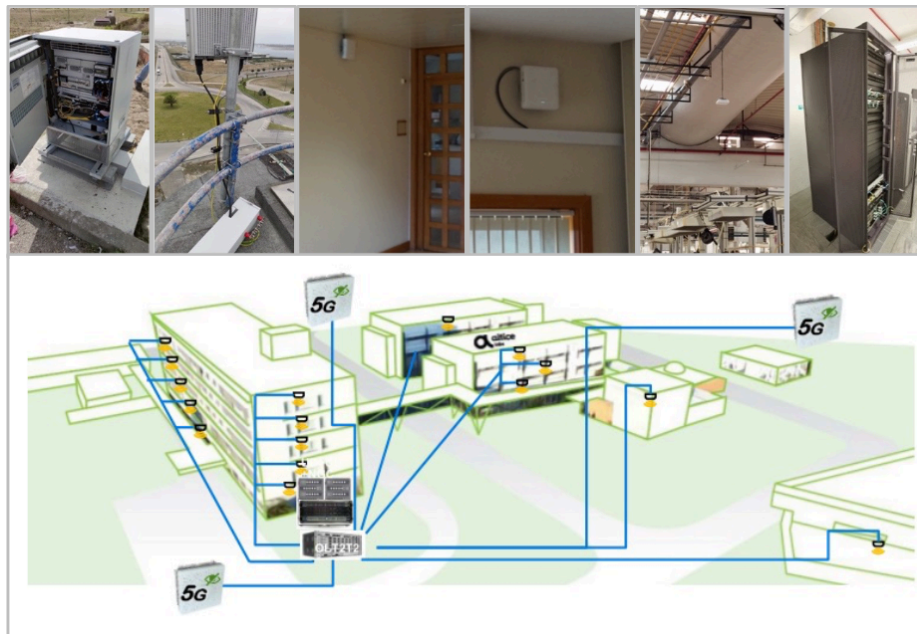

Figure 10: Portuguese facility RAN deployments

¹ <https://asocscloud.com/>

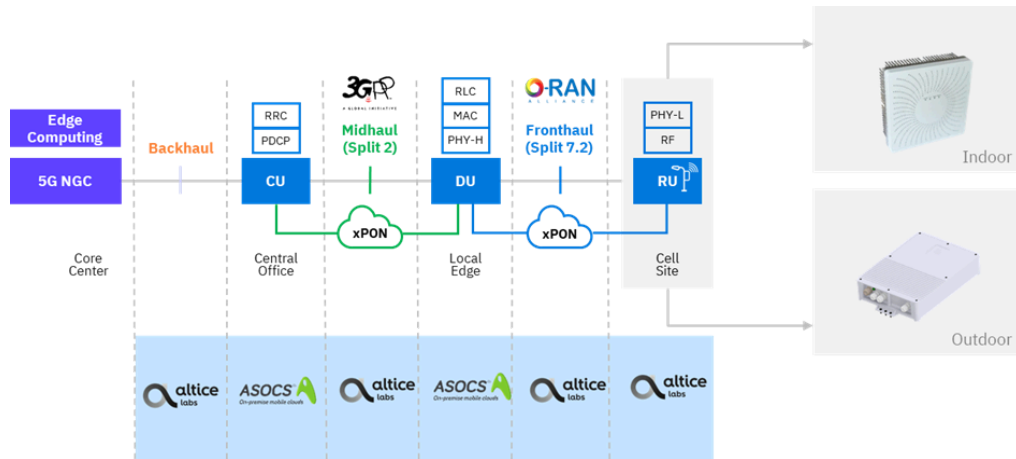

Figure 11: ASOCS-based indoor/outdoor infrastructure functional components

- Open-source OpenRAN Outdoor Network:** During OC1 the Portuguese facility will be extended to include a srsRAN Project based OpenRAN outdoor deployment. Utilising the same 20 MHz spectrum in band n78 the AlticeLabs campus will have three outdoor cell sites to cover a large area around the main building. The locations have been chosen such that overlapping cell areas will provide excellent coverage in mobile scenarios, i.e. when the connected devices move around the campus. Each site will be equipped with a Benetel RAN650 split 7.2a outdoor radio unit and a AlphaWireless AW3924 outdoor small-cell panel antenna for optimal radio performance. The figure below shows the antenna/RU mount location on the AlticeLabs main campus.

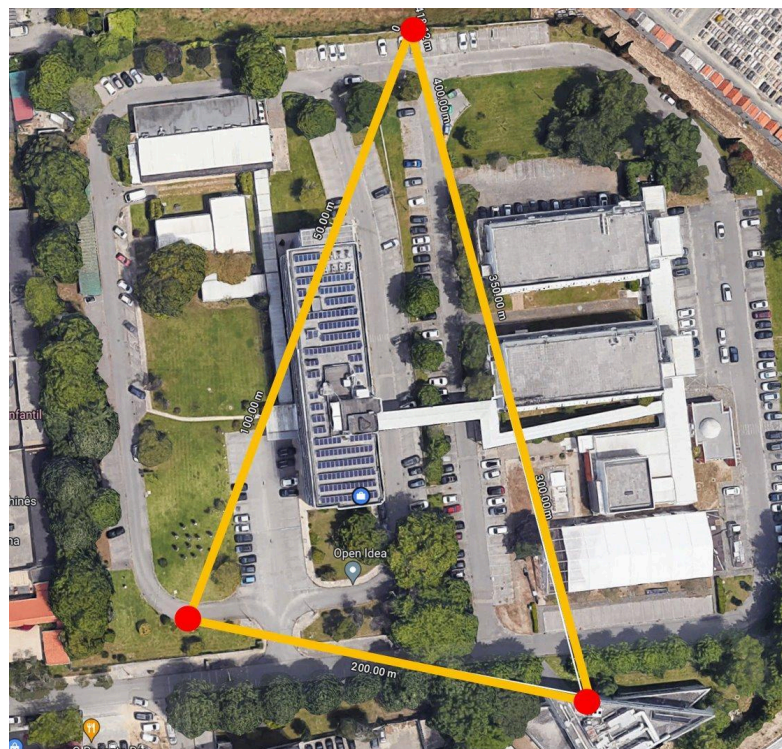

Figure 12: Outdoor cell location in point 1, 2 and 3 (large yellow triangle)

The extension will make all srsRAN Project features available to experimenters, including recent additions such as multi-cell and mobility. Furthermore experimenters will be able to modify a plethora of RAN parameters given the configurability of the RAN stack. This includes parameters in the PHY, MAC, scheduler, RLC, RRC and PDCP layer. For example the experimenter will be able to modify the TDD pattern to allow asymmetric assignments of downlink and uplink resources of the cell. For a full list of configurable parameters please see the official srsRAN Project documentation (<https://docs.srsran.com/projects/project/en/latest/>). The default configuration of the sites will be as follows:

- 20 MHz TDD (as per spectrum allocation)
- 30kHz subcarrier spacing
- MIMO: 2T2R, 2 layer DL, 1 layer UL
- TDD pattern: 7 DL slot, 2 UL slots, Short PRACH
- 256-QAM DL and UL

All three cell sites will be powered by a single server node that runs three DUs (one for each cell) and a single CU-CP. The RAN can be flexibly connected to different core solutions that are available at the facility, including open5gs or Druid's 5GC (see below).

As srsRAN Project also provides a standard-compliant E2 interface and supports the KPM and RC service models (SMs) experimenters will also be able to include RIC functionality in their experiments. Potential experiments are encouraged to use the extensive srsRAN Project documentation (<https://docs.srsran.com/projects/project/en/latest/>) as orientation.

Over the course of the project, the software version of the RAN will be constantly updated to receive features and improvements as they become available.

Under the platform extension of OC1 srsRAN Project will also receive 5G RAN positioning support. Those features are expected to become available during Q1/2025.

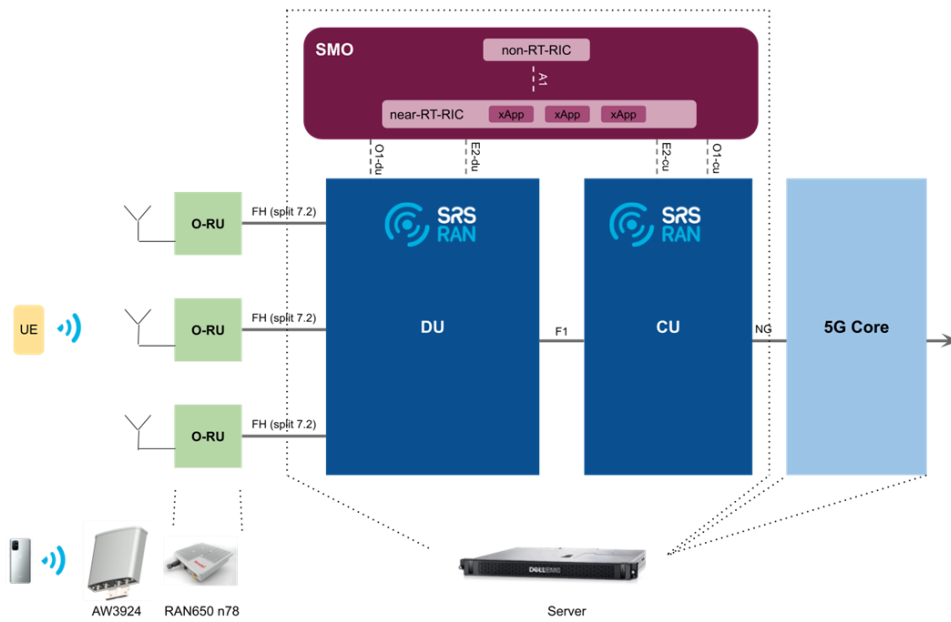

Figure 13: srsRAN Deployment split-7.2

The key functional components of the SRS-based Open-RAN infrastructure are represented in the figure below.

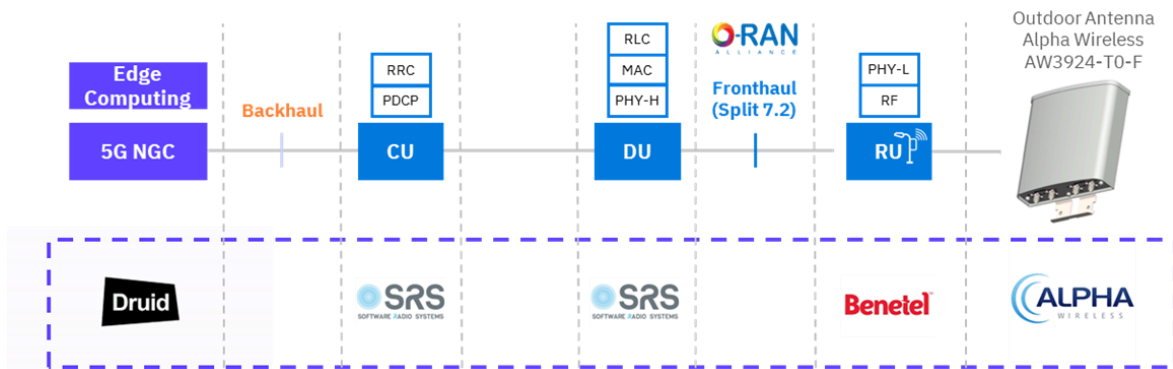

Figure 14: srsRAN-based outdoor infrastructure functional components

- **Core Network:** The four 5G SA cores listed below are available for use, depending on the specific characteristics and requirements of the use case:
 - Open5GCore² Release 6, provided by Fraunhofer Fokus' follows the service-based architecture and supports all fundamental 3GPP 5G core network functions. Open5GCore components can be deployed as containers or virtual machines.

² <https://www.open5gcore.org/>

- o Raemis³, a commercial 5G SA core provided by Druid, is especially designed for private networks, supporting 5G network slicing, URLLC traffic and a RESTful API to enable Management & Orchestration and integration of 3rd party applications.
- o Open5GS⁴, Free5GCore and OAI, open source 5G SA cores, supporting all major core components and following 3GPP Release 17.
- o Huawei 5G SA Core has some R17 functionalities and the following functions available: AMF, SMF, AUSF, NSSF, NRF, UDM, and UPF. This core supports custom network slices providing performance based on use case requirements, it also supports dynamic network slicing, being able to change network slice performance in run time without disrupting end device communication.
- **Cloud, Edge Computing Resources:** The site provides an edge computing capability, where latency-sensitive applications, such as XR can be deployed to take advantage of low latency conditions and improved bandwidth efficiency. Three edge computing platforms are currently available:
 - o Intel Smart Edge Open⁵, formerly Intel Open Network Edge Services Software (OpenNESS), has been validated through interaction with Open5GCore 5G core AF Network Function microservice.
 - o EdgeGallery⁶ supports capabilities that comply with ETSI MEC and 3GPP CAPIF and provides the MEC application developer tool chain.
 - o A Huawei MEC platform deployed in a remote industrial location and provides a dedicated LBO Edge UPF.

Additionally, Ubiwhere provides an edge operating system that can be flashed into far edge nodes and/or edge devices, allowing automated device and node discovery and control.

³ <https://www.druidsoftware.com/raemis-cellular-network-technology/>

⁴ <https://open5gs.org/>

⁵ <https://www.intel.com/content/www/us/en/developer/tools/smart-edge-open/overview.html>

⁶ <https://www.edgegallery.org/en/>

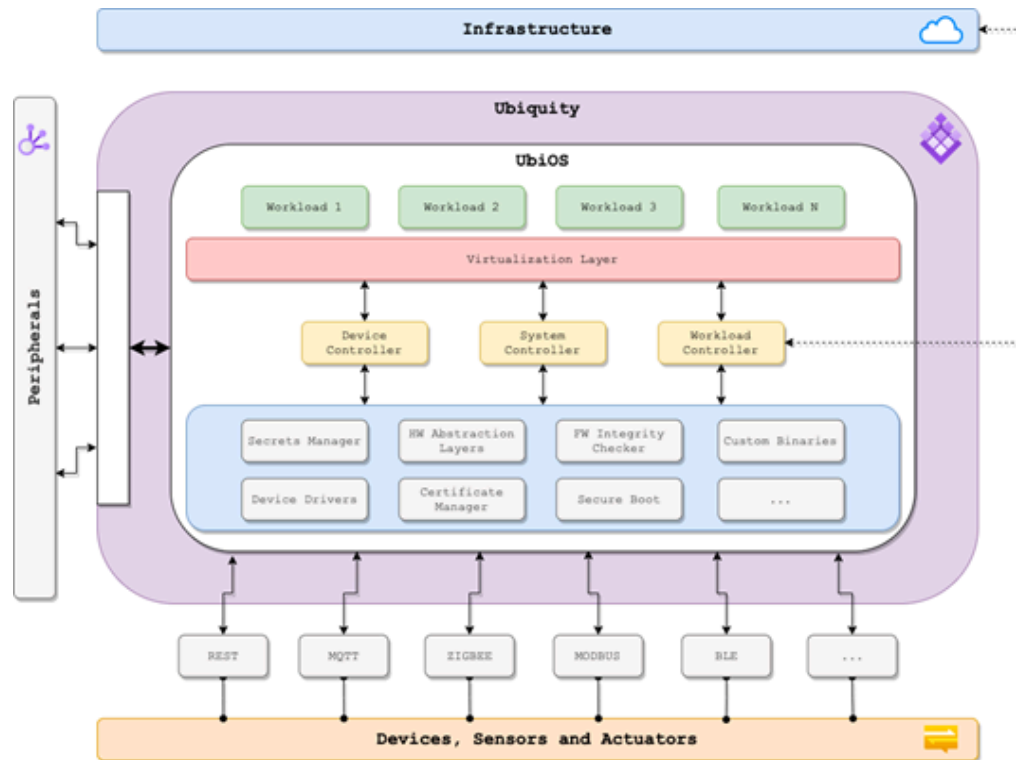

Figure 15: Ubiwhere's Zero Touch Management (ZMT)

- Control, Management, and Orchestration Platforms:** The different resources (e.g., RAN, Core, Edge, Cloud) are managed and operated by different solutions. On one hand, the commercial-graded 5G infrastructure (i.e., 5GC, 5G NR and 5G MEC) is monitored by means of a Huawei eSight platform as well as a Mobile Automation Engine (MAE) solution. The MANO role, currently played by OSM⁷, is responsible for receiving requests from other systems (e.g., service orchestration, OSS/BSS, portals) and orderly executing them on top of the available NFVI. An IoT Platform based on EdgeX by Linux foundation is provided by Ubiwhere, which provide supervision over Edge nodes with smaller processing capabilities such as NVidia Jetson Nano, Jetson Xavier or Raspberry Pi, depending on the type of application and data that needs to be processed closer to the devices, at the edge. Ubiwhere's IoT Platform functions at the data plane, by collecting data from devices such as sensors or video streams and in the control plane via health checks and the status of the edge nodes, through metrics such as CPU usage, RAM, or storage.
- Other Application-Level Solutions:** Ubiwhere's IoT Platform functions at the data plane, by collecting data from devices such as sensors or video streams and in the control plane via health checks and the status of the edge nodes, through metrics such as CPU usage, RAM, or storage. An IoT Platform based on EdgeX Froundry is provided by Ubiwhere, which includes management over Edge nodes with smaller processing capabilities such as NVidia Jetson Nano, Jetson Xavier or Raspberry Pi, depending on the type of application and data that needs to be processed closer to the devices, at the edge. Processing data locally brings several advantages, such as:

⁷ <https://osm.etsi.org/>

- o Lower latency by processing the data closer to where it is generated (sensors, cameras, etc.).
- o Data sovereignty and control of the data flow are achieved by maintaining the data locally on-premises.
- o Decrease cloud costs by moving the heavy processing and expensive tasks from the cloud to the on-site premises.

Besides the advantages of running workloads at the edge, the other side brings significant challenges due to the complex integration of different devices, sensors and actuators, connectivity gateways, edge nodes and all the corresponding software stack. Through Unicle, Ubiwhere uses open-source technologies with open interfaces that are key for the interoperability of systems, applications, and services to tackle the following challenges that can help application developers that want to interact with the Portuguese facility:

- o On the software side, UbiwhereUnicle provides the mechanisms to continuously integrate, test and deploy (CI/CD) new software versions into the existing infrastructure, i.e., the edge nodes and devices, or what is commonly called in the software industry as the production environment. This is particularly relevant to reduce the time-to-market of new software solutions, allowing you to be more efficient and productive in delivering your solutions. It's targeted for agile software development methodologies that advocate for smaller, more frequent release cycles and a closer feedback loop with the end customer/user.
 - o On the hardware side, it solves these challenges through our zero-touch automation solutions and by providing an abstraction layer between the hardware and the software stack; essential to have solutions that are compatible with a wide range of different devices and sensors, which avoids time-consuming changes and code rewrites, tests, and bug corrections every time a new type of hardware is used, relieving you of not having to deal with these stress-inducing tasks.
- **Security Architecture:** The facility features a security architecture following the best security practices and recommended security mechanisms, including physical access control, firewalls, and separate VPNs where the management and service planes are isolated. The connectivity to external sites is currently secured through encrypted VPNs with adequate access and integrity controls. In deployments where external entities are at play, the various third-party security policies from associated entities must be resolved alongside the existing internal policies so that the enforcement maintains compliance. In terms of 5G access networks, SIMs are programmed and managed by the relevant partner and a combination of APN and TAI are used for UL CL. During the development of IMAGINE-B5G (and after should it be further used beyond the project duration), the Portuguese facility will adopt new security mechanisms in line with the overall project security guidelines providing additional layers of defence as a fallback. Zero-Trust principles will be considered to provide a more secure experimentation environment for both testbed owners and experimenters, thus ensuring a duality of security perspectives.

- **Vertical/Developer Portal:** Openslice⁸ offers the interface for Network Application developers/experimenters and Verticals to interact with the facility services. Network Application developers will use the portal to onboard and instantiate their Network Applications.

ITAv provides a CI/CD Service capable of testing and validating Network Applications.

This service requires the developers to onboard a Testing Descriptor and Testing Artifacts. While the Testing Descriptor is a YAML file that defines each step of the validation process, the Testing Artifacts may comprise tests that shall be performed by a Test Execution Agent. Moreover, ITAv's CI/CD Platform allows for developers and experimenters to rely on broad-scope tests already available in the CI/CD ecosystem. This means that experimenters are not forced to onboard their own tests, since they can rely on the ones provided by the CI/CD Platform. An interesting outcome of this approach is that it paves the way for the development of certification mechanisms that rely on the tests offered by the platform to certify an application. During the validation of a Network Application, ITAv's CI/CD Platform can also gather network metrics and Application-level metrics/logs and provide them as an outcome of the testing process.

Vertical/Developer/Exposure APIs: Verticals may leverage the TM620, TMF 622, TMF633, TMF634, TM638, and TMF641 APIs. Through these APIs, Verticals may list and instantiate all Network Applications available in the Network Applications Marketplace. These are applications that were previously onboarded by the developers and validated through the CI/CD Platform introduced before. When listing all Network Applications available in the Marketplace, Verticals can also have access to the validation reports created by the CI/CD Platform, through which they can confirm that the Application has passed the intended tests.

Developers have access to the following APIs: TMF622, TMF633, TMF638, TMF640, TMF641, and TMF632. Through these APIs, Developers/Experimenters may onboard and manage their Network Applications and Testing Artifacts. Furthermore, Developers/Experimenters are also able to gather the validation process results from Openslice, through the abovementioned APIs.

⁸ <https://openslice.readthedocs.io/en/stable/>

4. French Facility (Eurecom, Samsung, Airbus, Keysight)

4.1 Facility Overview

EURECOM is located at the Sophia Antipolis science park within the SophiaTech Campus. Sophia Antipolis is Europe's largest and permanently expanding science and technology park. Open5GLab at EURECOM provides experimental 5G services including eMBB, URLLC, and mMTC. Based on fully open-source tools and open-architecture design, it provides the means to on-board new network functions to the running 5G infrastructure and test them in both a controlled laboratory setting and in a deployed live network. It is the main experimental playground for OAI and M5G SW packages. In addition, EURECOM will provide its open-source advanced 5G network-in-a-box, which will allow trials in locations outside the coverage area of the fixed infrastructure.

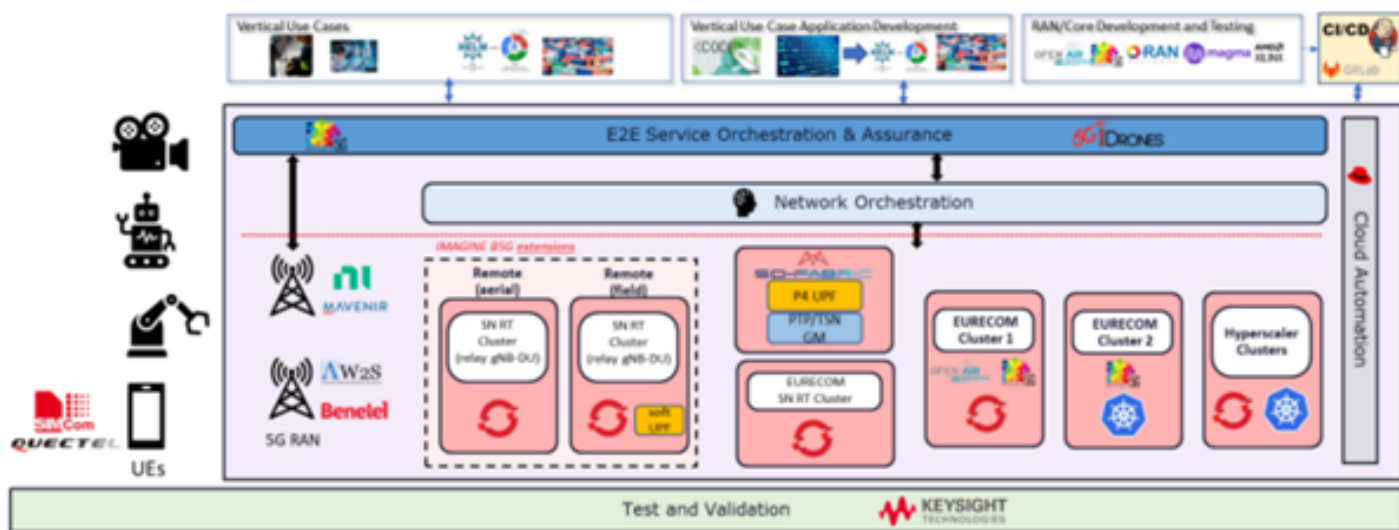

Figure 16: French facility components

4.2 Key Features

- **Radio Infrastructure:** The French facility RAN platform is based on OAI open-source software in both indoor and outdoor deployments.

1. FR1 RAN setup

The FR1 RAN platform is split to CU, DU and RU following two different functional splits.

- o (i) Split 7.2: OAI CU and DU uses commercial RUs from VVDN (indoor), LiteON (indoor), Benetel (indoor and outdoor)
- o (ii) Split 8: OAI CU and DU uses USRPs (B210, N300, X310, indoor) and commercial RUs from AW2S (indoor and outdoor).

The FR1 RAN setup operates at bands 38 (2.6 GHz) and 78 (3.4 GHz) supporting two subcarrier-spacing (15 and 30kHz), six different bandwidth sizes (10, 20, 40, 50, 80 and 100MHz) with multiple BWPs support (initial BWP and dedicated BWPs), different TDD configurations enabling asymmetric assignment of uplink and downlink resources with shorter TDD periods (down to 2.5 ms). It also includes the Procedures for 4-layer DL and 2-layer UL MIMO with the support of 256 QAM modulation. The outdoor coverage of the French facility is depicted in Figure 14.



Figure 17: EURECOM outdoor coverage

Figure 18 depicts the interfaces between different OAI components. The communication between OAI CU and DU is enabled using the F1 interface while the communication between DU and RU is enabled using: (i) eCPRI for AW2S; (ii) uhd for USRPs and (iii) O-RAN FHI for VVDN, LiteON and Benetel O-RU. The communication between the MAC layer and the High-PHY layer implements the nFAPI interface.

The CU and DU implement the E2 interface with the RIC. The implementation was tested with FlexRIC RIC⁹ that proposes the O-RAN compliant RCv1.3 and KPMv2 Service Models (SMs) and some customized SMs to support specific use cases such as dynamic TDD and slicing.

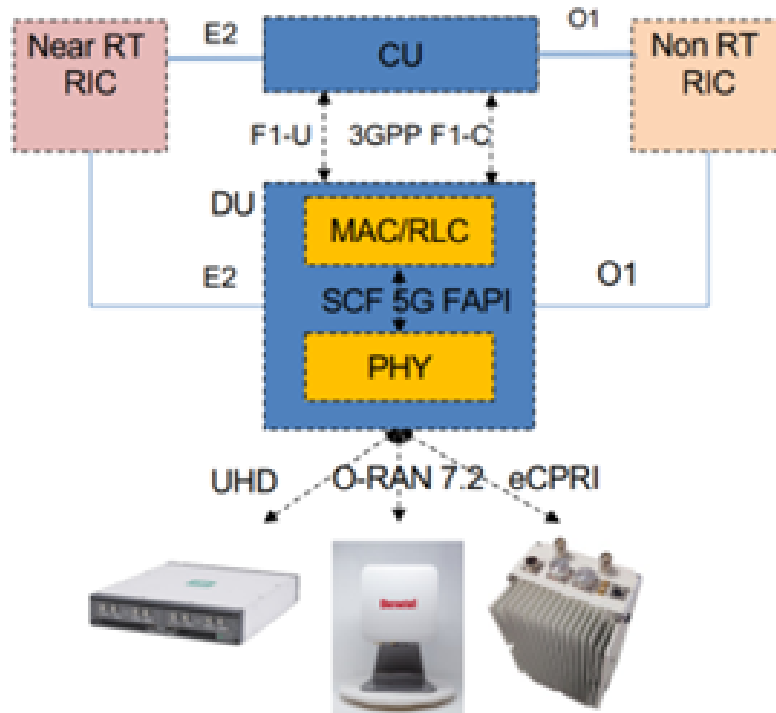

Figure 18: OAI and interfaces

- The minimal hardware setup for an O-RAN compliant system is shown in Figure 19(a). It comprises of:
- o two servers (one playing the role of the 5G core network and RAN control plane functions and another for the real-time gNodeB-DU)
 - o at least one O-RAN compliant O-RU radio unit
 - o a fronthaul switch with PTP support and an optional PTP grandmaster.

Note that some switches such as the FibroLan Falcon-RX can provide PTP grandmaster functionality when tuned with an external GPS signal.

⁹ <https://gitlab.eurecom.fr/mosaic5g/flexric>

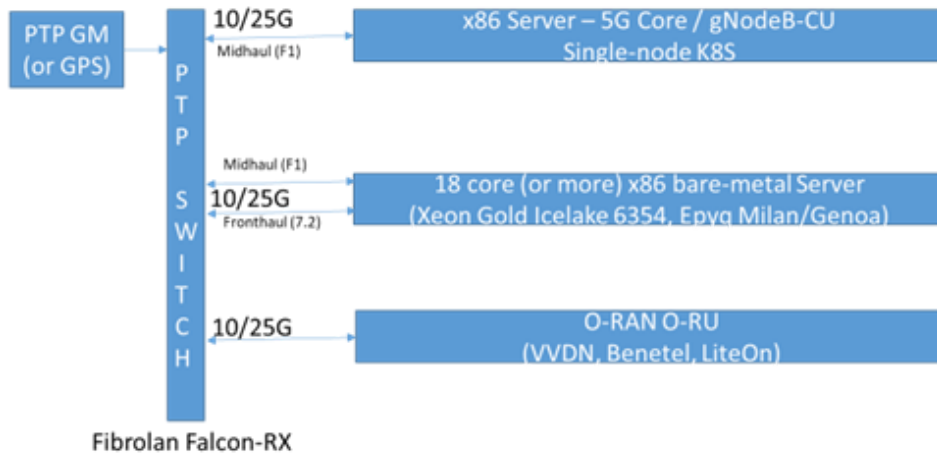

Figure 19(a): O-RAN equipment overview

Short Data Transmission (SDT) support:

During OC1, the French facility is extended by including the support of the 3GPP-compliant Two-step RACH feature to enable Short Data Transmission (SDT). The Random-Access Channel (RACH) is an essential mechanism used for initial access and connection establishment between a user device (UE) and the 5G network. The contention-based random-access procedure from 3GPP Release 15 is a four-step procedure. The Four-step RACH procedure requires two round-trip cycles between the UE and the gNB, which not only increases the latency but also incurs additional control-signalling overhead. The motivation for Two-step RACH is to reduce latency and control-signalling overhead by having a single round trip cycle between the UE and the gNB. This is achieved by combining the preamble (Msg1) and the scheduled PUSCH transmission (Msg3) into a single message (MsgA) from the UE, known as MsgA. Then by combining the random-access respond (Msg2) and the contention resolution message (Msg4) into a single message (MsgB) from the gNB to UE. The Two-step RACH feature is useful in scenarios where there are many IoT devices with sporadic and short data transmission needs, such as smart cities, industrial automation, agriculture, or environmental monitoring. The Two-step RACH helps reduce collisions and contention, making it more suitable for handling access requests from numerous IoT devices more efficiently. Moreover, some IoT applications require low latency for data transmission to ensure real-time responsiveness. For example, in industrial automation or vehicular communications, low latency is crucial for quick decision-making and coordination. The Two-step RACH can help reduce the time it takes for devices to establish a connection and start transmitting data, thereby reducing overall system latency.

2. FR2 RAN setup

FR2 is currently tested with USRP X410 and a 24-27GHz front-end radio unit developed by InterDigital (MHU) in a non-standalone (NSA) configuration. In parallel EURECOM will begin interoperability testing with the new FR2 O-RU developed by LiteON in June 2023 in both NSA and SA configurations.

The InterDigital MHU provides a single-beam per MHU using a 64-element array. A single USRP X410 can control 2 MHU to allow for two concurrent beams for OAI baseband processing. The MHU is capable of 200 MHz channel bandwidth although current testing with OAI is limited to single 100 MHz

channels. It provides 64 independent beams in three-dimensions with a horizontal opening of 90 degrees.

The LiteON FR2 O-RU provides two independent concurrent beams on the same 64-element (8x8) array with 49 dBm EIRP output power. It uses the O-RAN 7.2 fronthaul interface and operates as a Category-A O-RU providing 120 degree horizontal and vertical beamwidths. The unit operates in band n257 (26500MHz -29500MHz) with up to 400 MHz operating bandwidth. Beam selection is handled by the O-RAN 7.2 C-plane API. The LiteON FR2 O-RU will be operated using an identical setup to the FR1 system described in the previous section.

During OC1, the French facility will be extended with vision-sensing capabilities to allow the testing of Joint Communication and Sensing (JCAS) algorithms. A 3D video camera will be added on top of the Radio Unit (O-RU), creating a vision-aided gNB. An edge processing node will run computer vision algorithms to detect and classify the presence of objects that may block the Line of Sight (LoS) radio link. The computer vision will use a convolutional neural network (CNN) based YOLOv4 algorithm. Moreover, an intuitive web-based dashboard will be developed and integrated with the OAI mmWave indoor platform at Eurecom. The dashboard will have a user-friendly GUI that will work as an abstraction layer to facilitate the monitoring and controlling of the vision-aided 5G gNB. The dashboard will show real-time plots of network metrics per UE, including RSSI, RSRP, RSRQ, SINR, CQI, RI, PMI, PUCCH SNR, PUSCH SNR, Downlink/Uplink bitrate, MCS, BLER, etc. These metrics will be exportable to JSON format for further analysis and research. The OAI mmWave platform, extended with visual sensing, will be a state-of-the-art test facility for JCAS experimental research on emerging 6G use cases. The potential for innovation in the combined research area of wireless communications and computer vision is vast. Some examples include integrating vision, beamforming and RIS for coverage extension, high precision 3D positioning, vision-aided mmWave channel estimation, and advanced beam scheduler algorithms that take advantage of visual sensing.

The code source of OAI RAN is available here¹⁰. The documentation on how to deploy the RAN platform is available here¹¹. The documentation on how to deploy the RAN platform for O-RAN split 7.2 is available here¹².

3. O-RAN setup

EURECOM's ORAN interoperability testing configuration is shown in Figure 19(b).

¹⁰ <https://gitlab.eurecom.fr/oai/openairinterface5g/>

¹¹ https://gitlab.eurecom.fr/oai/openairinterface5g/blob/develop/doc/NR_SA_Tutorial_COTS_UE.md

¹² https://gitlab.eurecom.fr/oai/openairinterface5g/blob/VVDN_ORAN_fhi_integration/doc/ORAN_FHI7.2_Tutorial.md

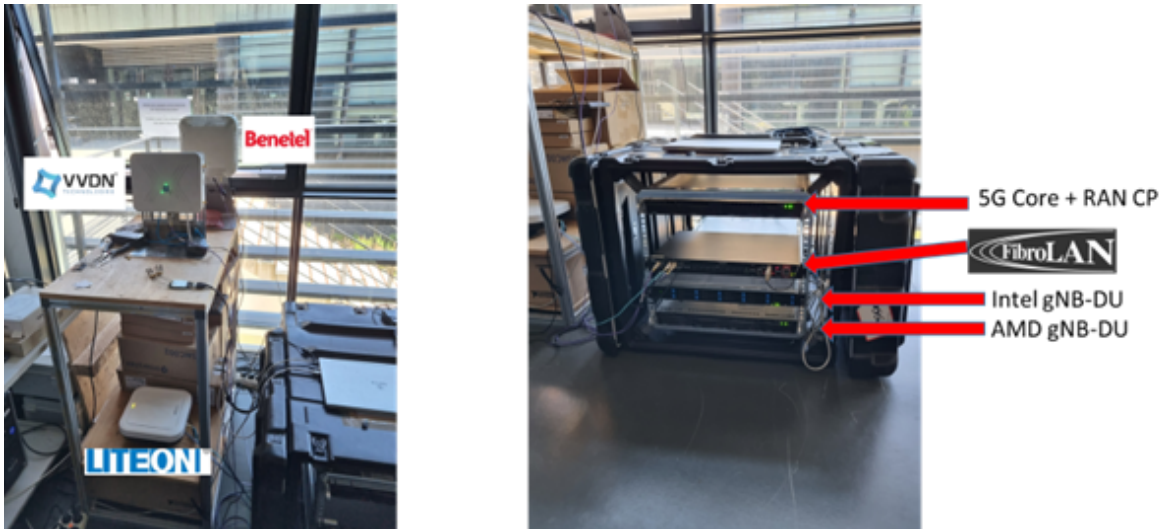

Figure 19(b): O-RAN Interoperability Testing Environment at EURECOM

FlexRIC is an O-RAN compliant RAN Intelligent Controller (RIC) in a form of software development kit (SDK) consisting of a server library and an agent library with two optional extensions: controller-internal Applications (iApps) and communication interfaces (refer to figure below). The objective of the SDK is to facilitate the realisation of specialised SD-RAN controllers to target specific use cases, while being simple to use.

The agent library is the basis to extend a base station with the agent functionalities. It provides an API to implement custom RAN functions, i.e., RAN functionality that can be monitored and/or controlled by applications, and comes with a bundle of per-defined RAN functions that implement a set of service models (E2SM) that can be included.

Currently, we are supporting two types of service models as follows:

- o Custom: including MAC, RLC, PDCP, RRC, NGAP, RAN Slicing (SC), and Traffic Control (TC) service models
- o O-RAN: KPM V3.01, RAN Control V1.03 and CCC (coming on Q2/Q3 2024)

For additional information visit: <https://gitlab.eurecom.fr/mosaic5g/flexric/-/wikis/home>

- **Core Network:** The core network solution is a partial 3GPP 5GC service-based architecture including the following Network Functions (NFs): NRF, AMF, SMF, UPF, UDM, UDR, AUSF, NSSF, PCF, NEF, NWDAF and CAPIF. Figure 17 depicts the CN architecture where the blue components are already available, and the orange components are under development.

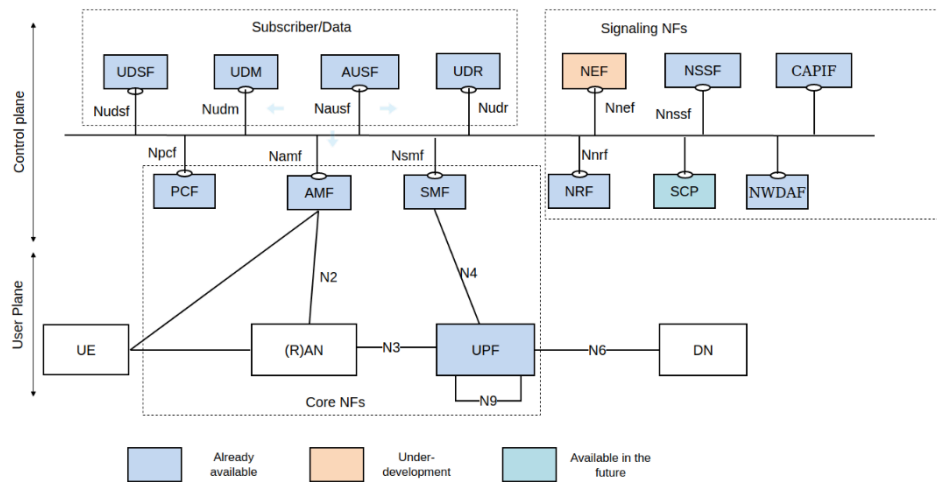

Figure 20: OAI 5G CN architecture

The core is fully open and configurable within the limitations of the OAI implementation. All the NFs can be deployed as docker containers either using docker, kubernetes or openshift. Each NF is initially configured using configuration files and can be configured during run time using exposed interfaces. The UPF can be deployed as a SW entity on a general-purpose machine (e.g., intel i7 CPU based machine) or as an application on a P4-programmable switching fabric. OAI 5G CN can be used with OAI gNB, RAN simulators (e.g., OAI RFSIM, UERANSIM, GnbSim, My5G-RANTester) and some commercial gNBs such as Nokia gNB and amarisoft gNB. OAI 5G CN also supports traffic steering using UL/CL UPF and PCF. The traffic can be forwarded to different UPFs according to the application IP address and hence allowing traffic steering toward different edges or the public cloud. The 5G CN is built on a Service-Based Architecture, which uses standardized service-based interfaces for communication between network functions (details in 3GPP TS 23.501). As a result, it is possible to create custom monitoring solutions to visualize events exposed by the 5G CN. In this context, one of the OC1 extension projects is to develop, test and demonstrate an OEM (Operations, Engineering and Maintenance) software to facilitate the management of the OAI 5G CN deployment. A web-based GUI will be developed as an abstraction layer to simplify the deployment, configuration, and termination processes of 5G CN instances. The proposed functionalities for the OEM include: Start/stop 5G CN button; Monitoring of events and KPIs for each CN Function; Start and terminating CN instances; Change CN configurations: PLMN, AMF region ID, Primary/secondary DNS, DNN, UE management and Management of network slices. This extension will be beneficial for IMAGINE-B5G experimenters for several reasons:

- Visualization: The GUI will provide a visual representation of the network's status and performance, making it easier for experimenters to quickly grasp the overall health of the 5G CN.
- Real-Time Monitoring: A GUI allows for real-time monitoring of various 5G CN functions, providing up-to-date information on network status, and performance metrics.
- Centralized Management: The GUI will centralize the monitoring and management of multiple 5G CN elements and services in one place.
- Alarm and Alert Management: The GUI can be configured to generate alarms and alerts based on predefined thresholds or events.

- Configuration and Troubleshooting: Experimenters can use the GUI to adjust settings, perform diagnostic tests, and make changes to the network.

The code source of the NFs is available here¹³. The documentation on how to deploy the whole CN is available here¹⁴. The documentation on how to use the traffic steering functionality is available here¹⁵.

- **Cloud, edge computing resources:** The site's cluster computing resource is split into several clusters used for different purposes, ranging from production use-cases for RAN/CORE/Edge, testing use cases and development. New clusters can be created reasonably easily, and network topologies are fully configurable using the facility's SDN switching fabric. Three types of clusters are currently deployed, (a) a full-scale K8S cluster making use of RedHat's OpenShift 4.9 container platform (OCP); (b) a single node RT OCP cluster used primarily for gNodeB-DU pods; (c) an experimental cluster to experiment with NFVO¹⁶ including machines configured as a vanilla K8S or OpenShift cluster and others for deployment of docker/podman containers. NFVO could also act as the E2E Service and Telco CNF Orchestrator to deploy all the services including one service for the UE. The OCP components benefit from technical support from RedHat. Some bare-metal nodes with in-lab 5G-capable radio devices (FR1 and FR2) are available as a sandbox that can be used by experimenters and developers and are interconnected with the three K8S clusters described above.
- **Control, Management and Orchestration platforms:** EURECOM provides three basic types of service orchestration functions for users. To allow for integration of vertical service SW directly on Open5GLab fabric, EURECOM makes a service creation and deployment framework available via a http-based portal, with which KPI and other monitoring services can be accessed. Local cluster orchestration is managed fully by RedHat OpenShift 4.9. Means for retrieving measurements in the RAN and Core CNFs are provided by an NFVO. Redhat's advanced cluster management framework was added to the infrastructure to allow for multi-cluster management and seamless addition of remote clusters to Open5GLab.
 - For a presentation, follow the link: <https://www.youtube.com/watch?v=90SRV9ZpPVo>
 - For a demo, follow the link: <https://www.youtube.com/watch?v=JoUgw4TOcyw>
 - We also added the support of intent-based requests. The vertical can express his requests via human language. For a demo, follow the link: <https://www.youtube.com/watch?v=SDyBge8WMt0>

Intent-Based Networking (IBN) is a promising paradigm for next generation networks, enabling automated network management based on user-defined business network requirements (Intents). However, current IBN approaches consider that users require expertise in some formal and

¹³ <https://gitlab.eurecom.fr/oai/cn5g/oai-cn5g-fed>

¹⁴ https://gitlab.eurecom.fr/oai/cn5g/oai-cn5g-fed/blob/master/docs/DEPLOY_SA5G_BASIC_DEPLOYMENT.md

¹⁵ https://gitlab.eurecom.fr/oai/cn5g/oai-cn5g-fed/blob/master/docs/DEPLOY_SA5G_ULCL.md

¹⁶ Arora, S., Ksentini, A., & Bonnet, C. (2024). Cloud native Lightweight Slice Orchestration (CLiSO) framework. *Computer Communications*, 213, 1-12.

technical models (e.g., Network Service Descriptors - NSDs) to define these Intents, necessitating substantial effort. A natural progression of IBN systems is to define Intents using natural language instead of structured models. However, dealing with this becomes challenging due to the unstructured and ambiguous nature of natural language. Fortunately, Large Language Models (LLMs) are becoming very powerful in understanding human language, making them well-suited for this task. In EURECOM’s facility, we implemented an LLM-based Intent translation system that allows users to express Intents in natural language, which the system subsequently converts into NSDs. Moreover, we employ a Human Feedback (HF) loop that enables the system to learn from past experiences.

- Security Architecture:** At the lowest level, EUR’s experimental infrastructure is behind HW firewalls with IPS and isolated from the Internet. Within the infrastructure access between projects and individual users is also isolated. EUR aims to limit its vulnerability to brute force password attacks and all accesses are logged for analysis purposes in the event of suspicious activity. External access is generally opened via secure shell access with trusted partners or through a VPN tunnel. In the event where a piece of trusted third-party networking equipment is deployed at EUR without the use of a VPN tunnel and is accessible via the internet for the purpose of measurement and control, operation is limited to a set of ports and protocols agreed upon with EUR in advance. Open5GLab aims to enforce a zero-trust policy when it comes to the use of third-party closed-source SW packages. When on-boarding third-party SW which is considered untrustworthy, Open5GLab limits deployment in anonymous user mode (i.e., without superuser privileges) on non-real time cluster nodes. In the event where an untrustworthy SW component requires superuser privileges for real-time operation, it is exceptionally deployed on a single-node cluster to limit any potential security breach to the node on which it is deployed.
- Vertical/Developer Portal:**
 For a demo, follow the link: <https://www.youtube.com/watch?v=JoUgw4TOcyw>

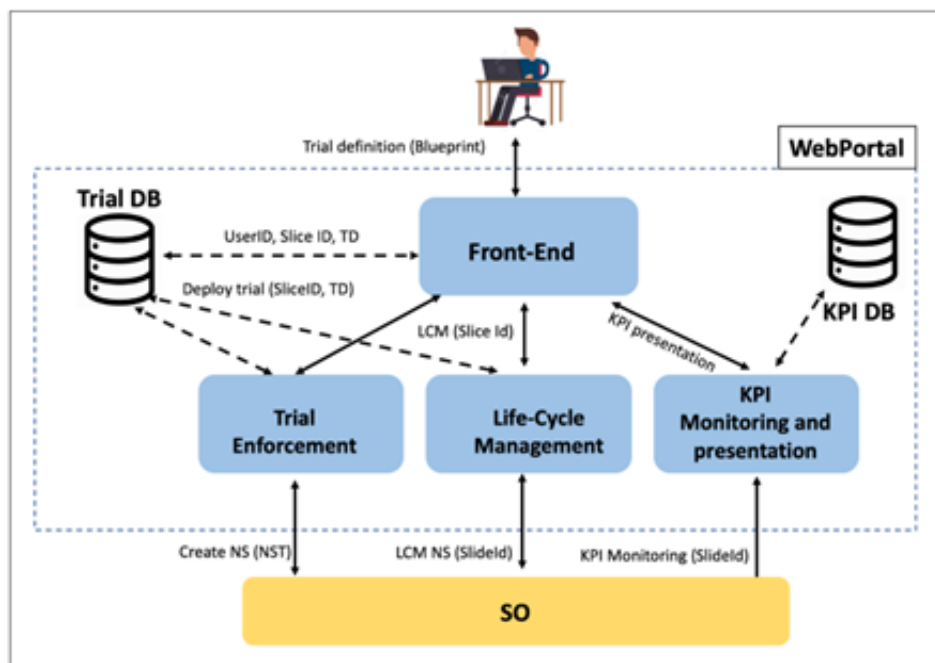

Figure 19: System Overview

The webportal is the facility's key element, as it is the interface with the vertical and trial owner. The webportal aims to abstract the 5G components by providing a high-level view of the trial management to the vertical, i.e., to deploy and monitor a trial. Figure 19 illustrates the webportal architecture, which comprises a front-end, trial enforcement, life-cycle management, and KPI monitoring and presentation, as well as two databases (DB). All the components collaborate to ensure the trial's life cycle, consisting of the definition and preparation, configuration and instantiation, run-time management, deletion, and monitoring.

- **Vertical/Developer/Exposure APIs:** The Slice Orchestrator API provides a set of endpoints to manage slices. This set of API endpoints allows for the creation, modification, and monitoring of slices, as well as retrieval of KPIs related to slice deployment and monitoring. By leveraging these endpoints, users can efficiently manage and monitor slices within their network infrastructure. The NFVO provides a Northbound REST API for managing and orchestrating services. This API offers a set of endpoints for resource management, service onboarding, service instantiation, service termination, service offboarding, service monitoring, service logs, and lifecycle operation status. By utilising these API endpoints, users can effectively interact with NFVO to perform various operations. Besides, as a part of OC1, the CAMARA APIs are being integrated into the French Facility. Among the new APIs, we will have: the Connectivity Insights API, the Device Location API and the Edge Cloud API. The Connectivity insights API has as primary function to offer customers the capability to define certain criteria, known as intents, as policy thresholds for Quality of Service (QoS) metrics related to both the device and the application service. The API service will alert the consumers if and when the policy has breached. The Device Location API Allows the management and tracking of geofencing areas and the devices within them. While the Edge Cloud API allows for the registration, management, and updating of applications within an edge cloud infrastructure.